

REVISIONS		
ISS	ZONE	DESCRIPTION\PER REQUEST\DATE

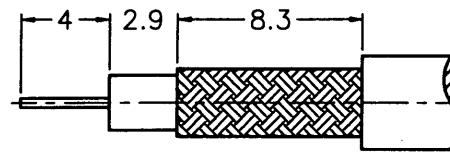

RECOMMENDED  
CABLE STRIPPING DIM'S  
(建議剝線尺寸)

SALEN

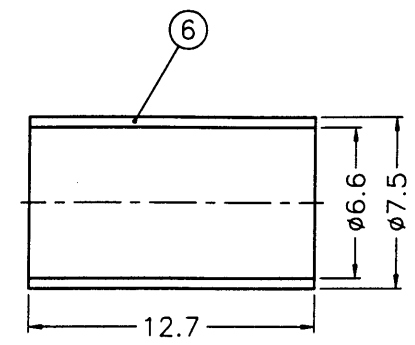
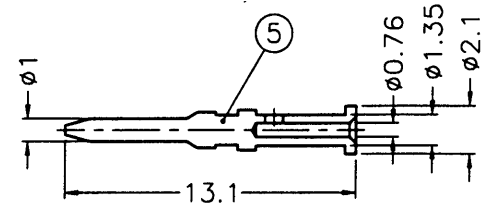
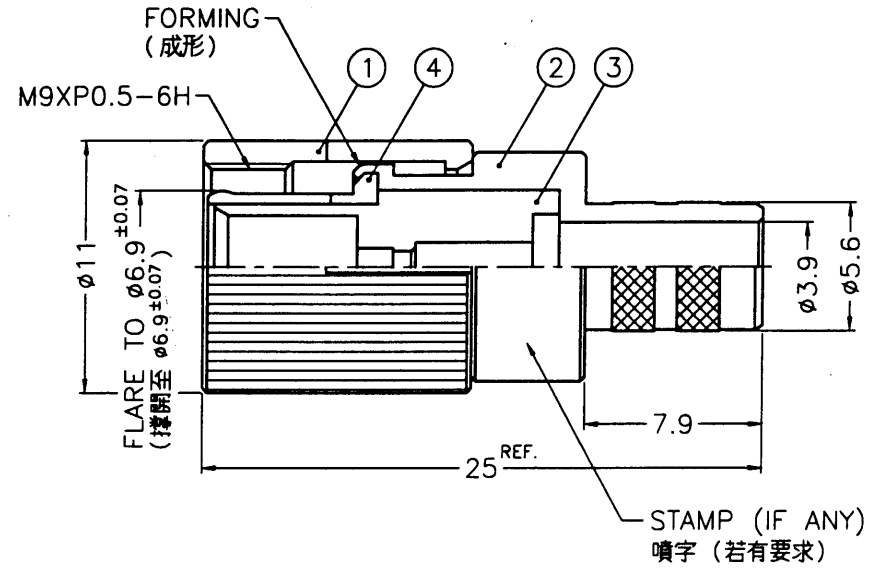

ISSUED  
2002. 8. 13  
R&D

- NOTES: FINISH (PLATING THICKNESS IN MICRO-INCHES)
- BRASS PER QQ-B-626
  - NICKEL PL. 100 MIN. THICK OVER COPPER STRIKE
  - PHOSPHOR BRONZE PER QQ-B-750
  - GOLD PL. 3 MIN. THICK OVER NICKEL PL. 100 MIN. THICK OVER COPPER STRIKE
  - TEFLON MIL-P-19468
  - JIS H 3250, C 2600

- CRIMPED FERRULE  
HEX CRIMP SIZE .255"
- CRIMPED CONTACT PIN  
SQ. CRIMP SIZE .043"

NO.	DESCRIPTION	MATERIAL	FINISH	Q'TY	DRAWING NO.	SCALE	3/1	ISSUE	A	FILE NO.	Amphenol - Kai Jack TAINAN TAIWAN			
6	FERRULE	NOTE 6	NOTE 2	1	FR-75/66X127	DIMENSIONS ARE IN MILLIMETERS UNLESS OTHERWISE SPECIFIED TOLERANCES 0.5-6 = ±0.2 6-30 = ±0.4 30-120 = ±0.6 120-315 = ±1 315-1000 = ±1.6 1000-2000 = ±2.4				PART NO.	APPROVED	DATE	TITLE	
5	CONTACT PIN	NOTE 1	NOTE 4	1	1561121A1-5-21 /076-B						1561121A1-5-21 /076-B	Andy. C	08-13-02'	1.6/5.6 CRIMP PLUG
4	OUT CONTACT	NOTE 3	NOTE 4	1	1561121G1-2							Andy. C	08-13-02'	DRAWING NO.
3	INSULATOR	NOTE 5	NATURAL	1	NS16AAS01A								08-13-02'	KJ-1561121A3-N/3GT3G-59U-75
2	BODY	NOTE 1	NOTE 2	1	1561121A1-2- 56/39								08-13-02'	ITEM NO.
1	SHELL	NOTE 1	NOTE 2	1	1561121G1-1-B								08-13-02'	161121AAC59NF7F
NO. DESCRIPTION MATERIAL FINISH Q'TY DRAWING NO. SCALE 3/1 ISSUE A FILE NO. F:\DWG\156\1121A3\59U-75\N3GT3G											7RD-DR 15202 8			